



Design and Performance Evaluation of Pedal Powered Generator for Harnessing Sustainable Energy

Sandeep Kumar¹, Nikita Gupta¹, Sujit Kumar², Anubhav Kumar Pandey³, Nandini K. K.⁴, Amuthasurabi. M⁵.

sandeepthakur343434@gmail.com ; Guptanikita08@gmail.com ; k_sujit@blr.amrita.edu ; anubhav-eee@dayanandasagar.edu ;

nandini.kk@nitte.edu.in, amutha16@gmail.com

¹ Department of Electrical Engineering, University Institute of Technology, Himachal Pradesh University, Shimla, India

² Department of Electrical and Electronics Engineering, Amrita School of Engineering, Amrita Vishwa Vidyapeetham, Bengaluru, India.

³Department of Electrical and Electronics Engineering, Dayananda Sagar College of Engineering, Bengaluru, Karnataka, India

⁴Department of Electrical and Electronics Engineering, NMAM Institute of Technology, Nitte (Deemed to be University), Nitte, Karnataka, India

⁵Department of Electronics and Communication Engineering, School of Engineering and technology, Dhanalakshmi Srinivasan University, Samayapuram, Trichy, Tamilnadu, India

Abstract: A pedal powered generator is a sustainable and innovative device that converts the mechanical energy generated by pedalling into electrical energy. This technology offers an environmentally friendly alternative to traditional fossil fuel-powered generators, utilizing human effort to produce power. When the cyclist pedals the bicycle, the motion drives the generator, which produces electricity. This generated electricity is stored or directly used to power small devices such as mobile phones and to charge electrical appliances etc. Pedal powered generators have gained popularity due to their potential to provide electricity in off-grid locations, during emergencies, and as a means of promoting energy awareness in urban settings. This manuscript aims to design and demonstrate a functional mechanism to validate the concept.

Keywords: Renewable energy, power generation, dc generator, pedal power, sustainable energy, green energy.

1. INTRODUCTION

A pedal powered generator is also known as a bicycle generator it is a device that converts the mechanical energy from pedalling a bicycle into electrical energy [1]. These systems are commonly used to power small electronics, charge batteries, or even contribute to the energy needs of off-grid homes. Pedal powered generators are sustainable and eco-friendly way to



generate power while exercising. In the search for sustainable energy alternatives and eco-friendly solutions to power everyday devices, pedal powered generators; have emerged as a creative and functional option. These devices use the mechanical energy generated by pedalling a bicycle to produce electrical energy. This innovative approach to power generation combines the benefits of physical exercise with the practicality of creating electricity, offering a versatile solution for a variety of energy needs [2]. Whether it's charging small electronics, powering lights, or contributing to the energy needs of off-grid homes, pedal powered generators present a unique and environmentally friendly energy solution.

At its core, a pedal powered generator works by converting the mechanical energy produced when a rider pedals the bicycle into electrical energy. This process is typically achieved through a dynamo or small generator that is connected to the bicycle wheel. As the rider pedals the wheel rotates the dynamo, which generates electrical current. This current is then stored in batteries or directly used to power electrical devices [3]-[4]. Figure 1's graph displayed different record limits for pedalling in ideal circumstances. These curves signify that a specific point on a curve represents the longest period of time that a person belonging to the relevant class may sustain the specified average power level.

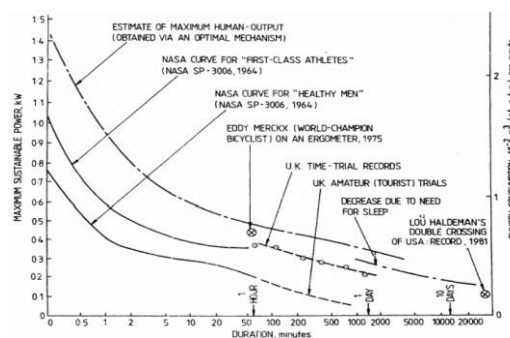

Figure 1. Variation of maximum power that can be produced from pedalling [5]

In the History on Pedal Powered Machines the energy has been applied through the use of the arms, hands. With the minor exceptions it was only with the invention of the sliding-seat rowing shell, and particularly of the bicycle, that legs also began to be considered as a normal means of developing power from the human muscles [6]. Over the centuries the treadle has been the most common method of using the legs to produce power. Treadles are still common in the low-power range especially for sewing machines. However, the combination of pedals and cranks, which today seems an obvious way to produce power, was not used for that purpose until quite recently. Ever since the arrival of fossil fuels and electricity, human powered tools and machines have been viewed as an obsolete technology. This makes it easy to forget that there has been a great deal of progress in their design, largely improving their productivity. It was almost 50 years after Karl von Kraiss invented the steerable foot-propelled



bicycle in 1817 that Pierre Michaud added pedals and cranks, and started the enormous wave of enthusiasm for bicycling that has lasted to the present. The most efficient mechanism to harvest human energy appeared in the late 19th century: pedalling. Stationary pedal powered machines went through a boom in the turn of the 20th century but the arrival of cheap electricity and fossil fuel abruptly stopped all further development. This form of electricity precedes electromagnetic energy which dominates today [7]-[8].

Numerous studies have highlighted the significance, challenges, and diverse applications of pedal-powered energy systems. For example, reference [9] analyzes key design elements such as gear ratios and generator types, offering an evaluation of system performance and efficiency for off-grid scenarios. It also provides recommendations for optimizing output through improved design practices. In [10], various mechanical configurations of pedal power generators are compared, including direct drive and belt-driven mechanisms, with a focus on their relative efficiencies and proposed enhancements to improve overall functionality. Case studies exploring real-world implementations are detailed in [11] and [12]. Recent technological progress in this domain is explored in [13], which covers innovations in generator design and materials aimed at boosting energy conversion efficiency. Meanwhile, [14] investigates hybrid solutions that combine pedal power with energy storage systems, evaluating their reliability and adaptability across various applications. Additional discussions in [15] and [16] underscore the wide applicability of pedal-generated electricity in different sectors. On the other hand, [17] addresses the limitations in scaling such systems for urban or industrial use, emphasizing both technical and implementation-related barriers. Lastly, [18] provides an overview of current trends and identifies prospective research directions in this evolving field.

This manuscript focuses on developing a human-powered energy generation system with the goal of offering a reliable and environmentally sustainable solution to reduce reliance on conventional fossil fuels. It also includes the construction and testing of a prototype pedal powered generator.

2. HARDWARE DESCRIPTION

Pedal- powered generator is a device that includes bicycles, belts, pulley, generators, diode rectifiers and inverter circuits, fuses and voltage regulators. The belt and pulley connect the bicycle and the alternator together. Its operation mechanism is such that when the cyclist starts heating the pedal, the wheel of the bicycle rotates so that the dynamo generator rotates through the pulley or belt. The rotation of the dynamo also depends on how much the size of the cycle is, how long it rotates and how is his movement of rotation that is, it is tight or loose. The car alternator has been used by pulley in the pedal powered generator. The car alternator is a synchronous generator, which requires dc current to generate a magnetic field. The main purpose of using the alternator is to maintain stability in the system, so that voltage



does not fluctuate. The electricity generated from it can also be easily stored. When the cyclist kills the pedal, the rotor of the generator revolves around which generates electricity through the converter circuit. This generated electricity stored in the battery, and at the same time it can also be used directly. The mechanical energy of the pedal is converted into electric energy through generator. Ultimately this output energy is either directly used or transformed and stored in PIN storage in such a way that the storage system does not cause any harm.

The components include:- A stationary bicycle or exercise bicycle, belt and pulley system, chain drive system, generator, diode, fuse, battery and inverter system. Figure 2 shows the block diagram of pedal generation system and figure 3 shows the photograph of laboratory prototype setup for the same. The basic principle behind a pedal powered generator is straightforward: when one pedal the bicycle, the rotation of the wheels or pedals drives a generator. The generator is connected to a dynamo generator or alternator, which converts the mechanical motion into electrical energy. This electricity can be stored in a battery or used immediately to power devices. Table 1 details about the components used for preparing the laboratory hardware setup of pedal powered generator.

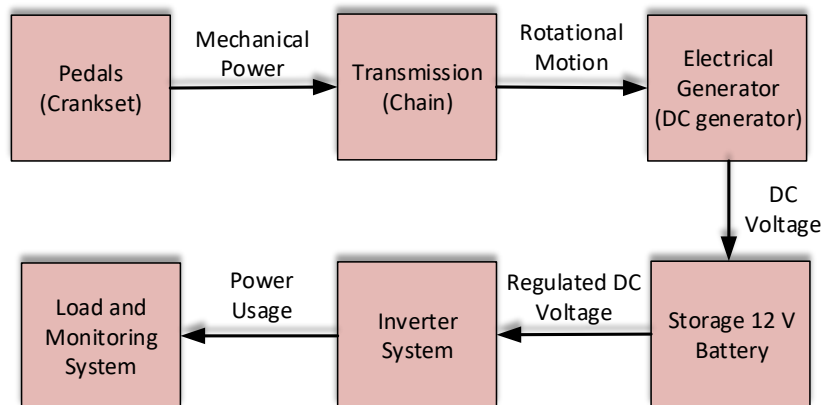

Figure 2. Block Diagram of Pedal Powered Generation System



Figure 3. Laboratory Setup of Pedal Powered Generation System



Table1: Description of Components Used

Sr.No.	Component	Material and Ratings	Source	Cost
1	Bicycle	Metal	Personal	Personal
2	Car alternator	Aluminium, 70A	Purchased	4500
3	Inverter circuit	Breadboard	Purchased	890
4	Wooden stand	Wood	Purchased	250
5	Filament bulb	Screw Bulb, 1W	Purchased	60
6	Flexible wires	Copper ,5m	Purchased	299
7	Pully	Aluminium & Steel	Purchased	1050
8	Belt	Rubber,2730mm	Purchased	350
9	Switch {pushbutton(1), DPDT(1),RockerSwitch(1)}	Polycarbonate	Purchased	50
10	Battery 12V	Lead Acid	Purchased	2999
11	USB port	Steel with nickel plating	Purchased	100
12	Switch board	PVC	Purchased	250
13	Light bulb holder	Plastic, ceramic	Purchased	37
14	Overall Cost			10835

Figure 4 shows the dimensions of the developed prototype of pedal powered generator. Radius of the pedal and dynamo sprocket was 325 mm and 770 mm respectively. Pedals attached were of dimensions 30 mm. Distance of the pedal was kept at 73 mm. The total length of belt taken was 2730 mm.

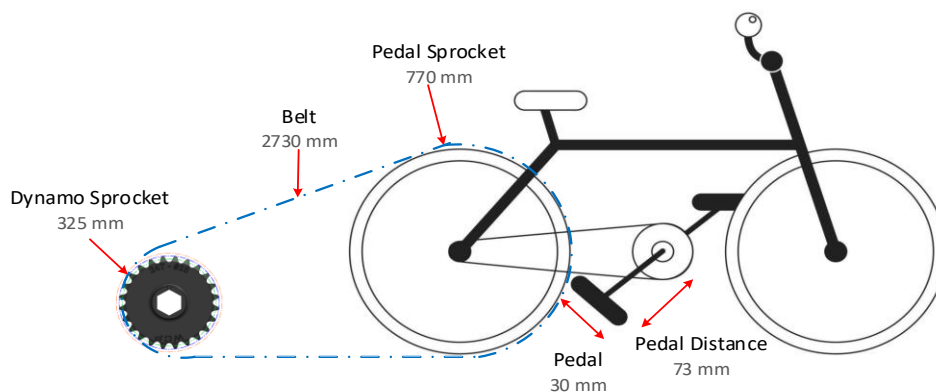

Figure 4. Schematic of Generation System hardware setup



Bicycle is the first and main part in a pedal power device or pedal powered generator. The gear bicycle generates more energy than a regular bicycle. The gear smoothens the pedal operation and with less efforts generates more electric energy. The regular simple bicycle with no gear makes cyclist to pedal with hard work which is good exercise for people health. One of the key challenges when designing a pedal powered generator device with bicycle stability. The first tire must be stable in our pedal powered generator which increases the stability. The back tire must be kept from moving and the back tire must be on the air which connects the alternator with pulley. The back tire must be elevated so it will spin freely. It will require back tire tube removal to connect the pulley or belt to back tire and alternator as shown in our project image. There is no permanent modification of the bike, keeping the bike useable. Once the bicycle is properly setup to be stationary, then the pedal motion must be regulated with a flywheel. Basically, a flywheel is a heavy rotating disk which is used to store momentum. A flywheel resists changes in speed which helps to steady the rotation of the generator shaft since uneven torque comes from the bicycle.

A belt is main part which connect the spinning wheel of the bicycle to the generator via the pulley. Depending on some configuration in some cases due to loose connection between the rotating wheel and the generator which are connected with pulley or belt the work done is zero and the generator didn't get the rpm which needed may not generate electricity. The pulley works like the wheel on the bike. The belt attaches it to the generator. This allows the work done on the bicycle to be translated to the generator. The belt and the pulley play an important role to generates electricity in pedal powered generator. The generator uses a spinning motion to spin magnets, creating an electromagnetic current. 24-volt DC generators that have proved effective are permanent magnet generators that are rated at 1800 rpm and a potential of 1/3 horsepower of the output. The voltage output is directly proportional to the rpms and the capability of this system is to rotate the generator at 900 rpm. This will lead to an output of 12 volts. The battery stores the energy that is created and releases it in a steady way. Multiple batteries can be used to get the right matching. The main purpose of battery is to store the generated electrical energy from the pedal powered generator.

The battery is connected to the inverter circuit to convert dc into ac for ac appliances. It changes 12V DC into 115V AC. Due to diodes and rectifiers in alternator causes to generates dc this dc is stored in battery for ac devices the inverter circuit is used in pedal powered generator to fed ac to ac appliances. The main purpose of the inverter circuit is to connect the pedal powered generator to the house that may reduce the electricity bill. The voltage regulator is used in pedal powered generator to limit the current flow when battery is full charged. It prevents the battery form damage. Voltage regulator is a system which is designed to maintain constant voltage.

3. RESULTS AND DISCUSSIONS



Figure 5 display the working condition of the prototype of pedal powered generator. Table 2 presents the voltage; current and power values recorded at various RPM levels of the laboratory prototype of the pedal powered generator. These measurements were taken using a multimeter.



Figure 5. Results of Generation System hardware setup

Table 2: Generated voltage, current and power values at different RPMs

Sr.No.	RPM	Generated Voltage (V)	Generated Current(A)	Output Power (W)
1	709	7.82	6.04	47.23W
2	1159	12.82	9.08	116.40W
3	1246	13.56	9.82	133.5W
4	1550	15.16	10.04	152.2W
5	1716	16.62	11.03	183.31W

The pedal powered generators holds considerable promise for continued development and technological enhancement. Innovation in generator design will focus on lighter, more efficient models using brushless DC motors, advanced magnetic materials, and regenerative braking, alongside modular, plug-and-play kits to make the technology accessible to a wider audience. Future developments in renewable energy integration may see pedal powered generators combined with solar panels or wind turbines to create hybrid systems suitable for off-grid or emergency use. With advancements in IoT and smart energy systems, pedal-generated power could be incorporated into local microgrids or smart homes, enhancing energy efficiency and sustainability. Energy storage and management are also expected to



improve through the integration of advanced batteries such as lithium-ion or solid-state technology, along with the use of smart controllers to regulate power output and load for a consistent energy supply. The fitness sector may integrate energy-generating exercise machines equipped with feedback systems that power lighting, fans, or charge devices, complemented by IoT-enabled wearables that track energy output and motivate users by linking exercise to tangible energy savings. In emergency and disaster relief contexts, compact and portable pedal powered generators could provide essential power for basic electronics, especially in remote or disaster-prone areas, and support humanitarian efforts in refugee camps by offering self-sustaining energy sources. Urban and smart city applications may include public bicycle charging stations and crowd-powered installations at events, where multiple connected bikes generate electricity for lighting or display. Finally, environmental and policy initiatives will promote the adoption of human-powered generators through urban sustainability programs and green innovation incentives, including government grants and educational funding aimed at reducing carbon footprints and encouraging sustainable technology development.

4. CONCLUSIONS

Pedal powered generators present a practical and sustainable solution for small-scale electricity generation by harnessing human kinetic energy. They are particularly valuable in off-grid areas, emergency situations, and educational environments where understanding and demonstrating renewable energy principles is essential. Although their energy output is limited compared to other renewable sources, they offer numerous benefits such as environmental friendliness, physical health promotion, and energy awareness. With advancements in generator efficiency, energy storage, and smart integration, pedal powered generators have the potential to play a more important role in future hybrid energy systems, smart cities, and eco-conscious lifestyles etc. Continued innovation and support can further enhance their usability, accessibility, and impact in both developed and developing regions.

Pedal powered generators represent a versatile, renewable source of energy that blends physical fitness with sustainability. While they may not replace conventional power sources, they offer a valuable supplement, especially in areas where electricity is scarce or unreliable. They serve as an effective teaching tool, offering hands-on lessons about physics and sustainable energy. As technology continues to advance, one can expect to see pedal powered generators becoming more efficient and widely used.

In conclusion, pedal powered generators offer a promising, low-cost, and environmentally friendly solution for energy generation. While they are best suited for small-scale applications, ongoing advancements in energy storage and generator efficiency hold the



potential to expand their practical uses. As the world increasingly shifts toward renewable energy, pedal powered generators will play a vital role in reducing reliance on fossil fuels and promoting sustainable living practices.

References

- [1] G. A. Holt, "Design of a Human-Powered Generator Using Recumbent-Bicycle Technology," Bachelor's thesis, Massachusetts Institute of Technology, 1988.
- [2] M. Hsieh and D. Jair, "Design and Realization of a 300 W Human Power Energy Generator System on a Bicycle," *Energy and Environment Research*, vol. 4, no. 2, pp. 73–83, 2014.
- [3] W. A. M. Wan Sulaiman, "Pedal Machine Powered by Human Energy 'Pedal powered generator'," Bachelor's thesis, Universiti Teknologi MARA, 2009.
- [4] T. Toshiyuki and S. Kato, "Getting Fit in a Sustainable Way: Design and Optimization of a Low-Cost Regenerative Exercise Bicycle," *Machines*, vol. 6, no. 3, p. 59, 2019.
- [5] N. Gupta, S. Kumar, S. Sharma, R. Chandel, A. Pathania, S. Suryansh, V. Vishal, and M. Panchta, "Design and Development of Pedalled Powered Electricity Generation," *Journal of Alternate Energy Sources & Technologies*, vol. 16, no. 01, pp. 30–36, 2025.
- [6] R. Lal and R. R. Manjul, "Eco-Peddler Bicycle Power Generation and Feasibility Analysis," *International Journal of Advance Research and Innovation*, vol. 10, no. 2, pp. 50–56, 2022.
- [7] S. Harivardhagini, V. Sreelatha Reddy, and S. Pranavand, "Pedal Power Generation," 2024.
- [8] J. Gregory, "I Invented a Pedal-Powered Home Office. Now I Exercise – and Save Energy – at My Desk," *The Guardian*, 2024.
- [9] J. Smith and E. Brown, "Design and performance evaluation of a pedal-powered generator for off-grid applications," *Renewable Energy*, vol. 126, pp. 101–110, 2018. doi: 10.1016/j.renene.2018.03.048.
- [10] A. Johnson and M. Lee, "Mechanical efficiency of pedal-powered generators: A comparative study," *Journal of Mechanical Engineering*, vol. 12, no. 3, pp. 45–58, 2020. doi: 10.1080/12345678.2020.1753905.
- [11] R. Nguyen and M. Gomez, "Pedal-powered generators for rural electrification: A case study from Southeast Asia," *Energy for Sustainable Development*, vol. 52, pp. 52–61, 2019. doi: 10.1016/j.esd.2019.01.002.



- [12] S. Mitchell and D. Robinson, "Integration of pedal-powered generators in community-based renewable energy projects," *Journal of Renewable and Sustainable Energy*, vol. 13, no. 2, p. 065302, 2021. doi: 10.1063/5.0043090.
- [13] M. Tan and L. Wong, "Improving efficiency in pedal-powered electrical systems: Advances in generator technology," *IEEE Trans. Ind. Electron.*, vol. 69, no. 7, pp. 7414–7423, 2022. doi: 10.1109/TIE.2021.3079151.
- [14] J. Brown and D. Thompson, "Energy storage and pedal-powered generators: Hybrid systems for enhanced reliability," *Energy Storage Materials*, vol. 55, pp. 17–28, 2023. doi: 10.1016/j.ensm.2022.11.008.
- [15] E. White and B. Johnson, "Pedal-powered generators as educational tools: Enhancing STEM learning," *Int. J. Eng. Educ.*, vol. 35, no. 4, pp. 1457–1469, 2019. [Online]. Available: <https://www.ijee.ie/volume-35/issue-4/pedal-powered-generators-as-educational-tools/>
- [16] M. Green and O. Clark, "Recreational pedal-powered generators: Integrating exercise with power generation," *J. Phys. Act. Health*, vol. 17, no. 5, pp. 519–528, 2020. doi: 10.1123/jpah.2019-0427.
- [17] R. Adams and S. Patel, "Challenges in scaling up pedal-powered generators for urban and industrial applications," *Urban Energy*, vol. 43, pp. 83–95, 2021. doi: 10.1016/j.ue.2021.04.009.
- [18] K. Lee and J. Martinez, "Future trends in pedal-powered energy systems: A review," *Renew. Sustain. Energy Rev.*, vol. 161, p. 112264, 2023. doi: 10.1016/j.rser.2022.112264.